

# The SOHO Spacecraft Model

This paper model (pages 2-4) can be printed in color or black and white on 8.5 x 11 inch paper and assembled in about 25 minutes. A heavier stock paper will make the model sturdier but is not necessary. All you need are glue, scissors, a toothpick, and an optional piece of clay for the base.

We have included a page of images of SOHO so you can get an idea of what it really looks like, a photo of the completed model, and two SOHO images of the Sun.

The last page shows the 12 instruments on SOHO, what they do, and roughly where they can be found on the model. (Not all instruments could be represented.)

Good luck and enjoy your model-making!

---



## More about SOHO --

SOHO (**The Solar and Heliospheric Observatory**) is a joint international space mission carried out by the European Space Agency (ESA) and the US National Aeronautics and Space Administration (NASA). It is part of the larger International Solar-Terrestrial Physics program (ISTP). SOHO's major goal is to enable scientists to solve some of the most perplexing riddles about the Sun, including the internal structure of the Sun, the heating of its extensive outer atmosphere, and the origin of the solar wind.

SOHO was launched by an Atlas-Centaur rocket on December 2, 1995, and is one of the most ambitious space study missions to date. Its sophisticated array of twelve instruments was developed by European and American scientists. Large engineering teams and hundreds of scientists from many countries support the operations and analysis. Large radio dishes around the world, which form NASA's Deep Space Network, are used to track the spacecraft beyond the Earth's orbit. Mission control is based at Goddard Space Flight Center in Maryland.

SOHO's uninterrupted view of the Sun is achieved by positioning it at a permanent vantage point 1.6 million kilometers sunward of the Earth, where the gravitational forces of the Earth and Sun keep SOHO in an orbit locked onto the Sun-Earth line. By observing the Sun continuously for over five years and sending back millions of images and far ranging data, SOHO is helping us to understand the interactions between the Sun and the Earth's environment better than ever before.

*Thanks to Erik te Groen and staff of the Public Observatory, Philippus Lansbergen, Netherlands, for their original inspiration and assistance in creating the model design.*

# *Make a Paper Model of SOHO*

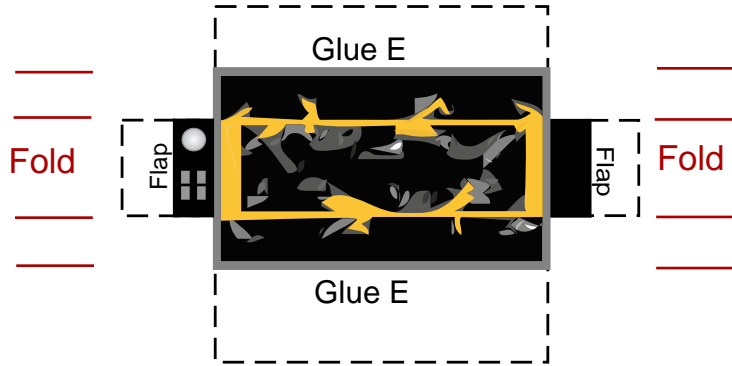

E

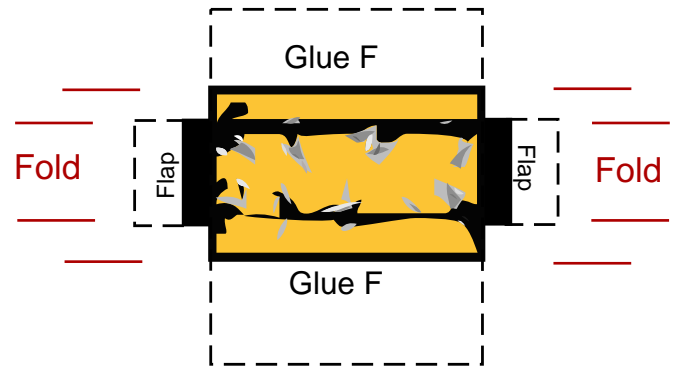

F

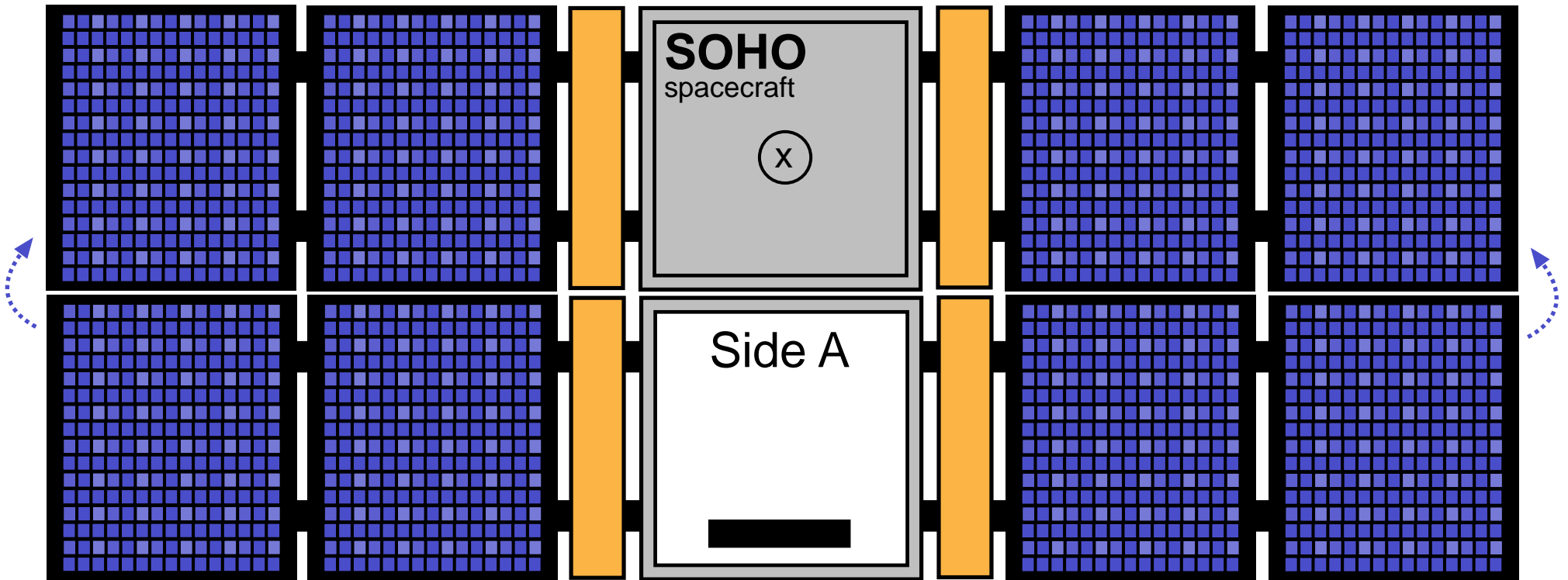



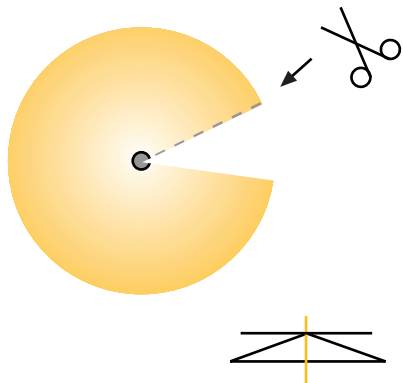
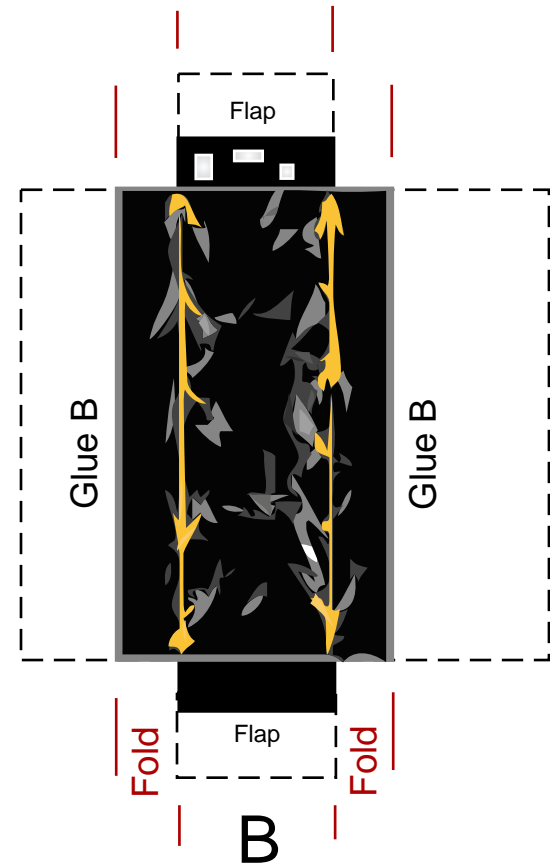
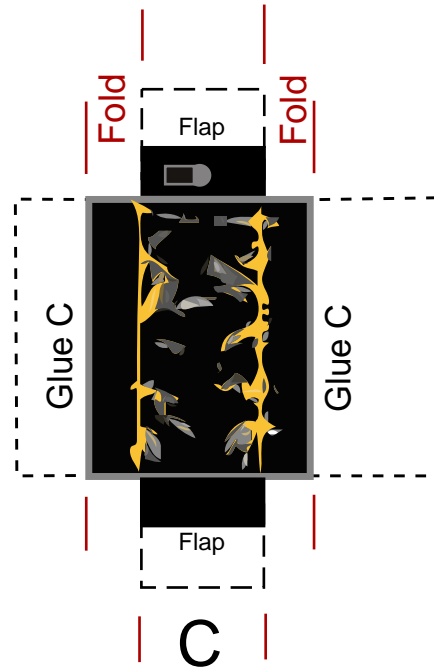
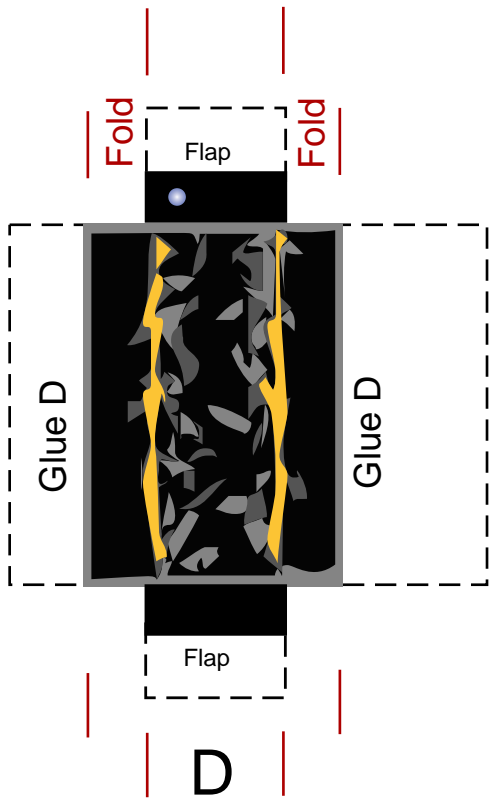

Single cut, overlap the white slice and glue. Stick toothpick through center of communications dish and the "x" at bottom of blue solar panels. Extend it if inserting in something like a clay base or model can just sit on the dish.

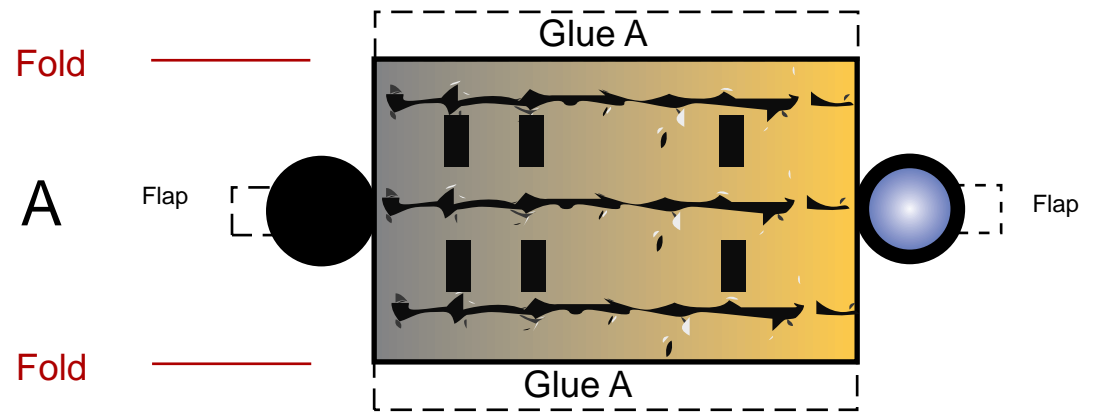

Fold at fold lines and roll up A

SOHO under construction

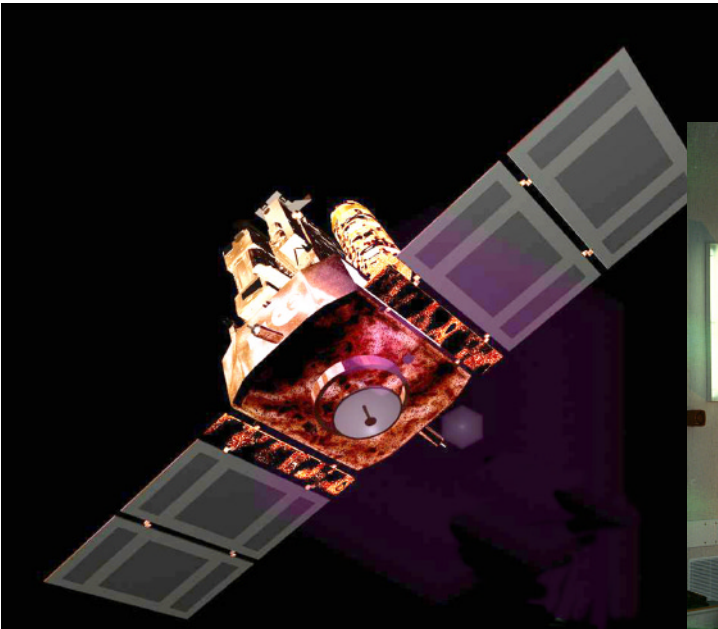
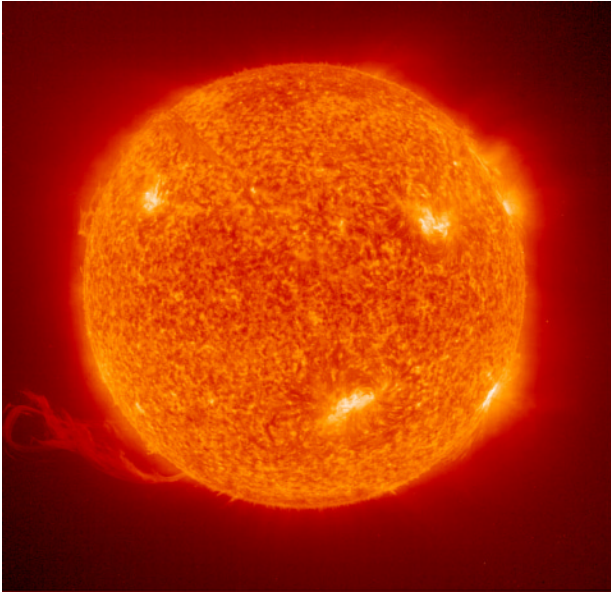
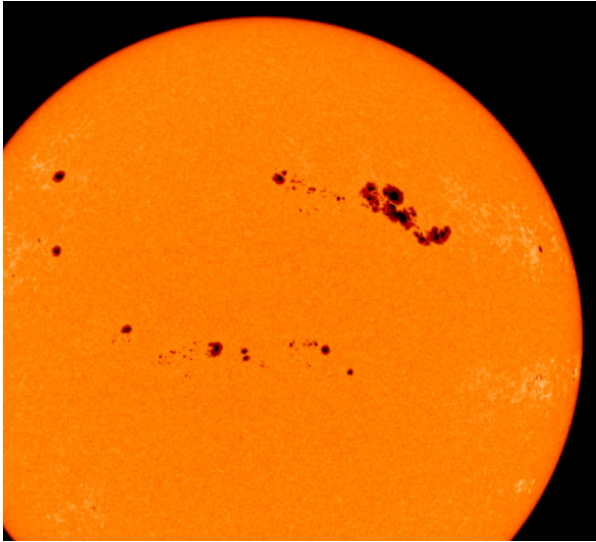

Illustration of SOHO in flight



SOHO image of the Sun in extreme ultraviolet light



A large sunspot group seen by SOHO

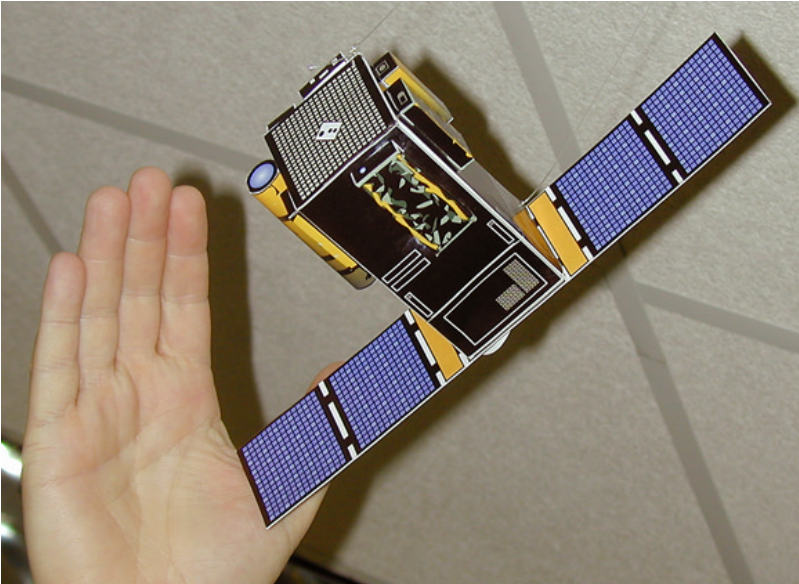

The paper SOHO model as it looks when completed

# The SOHO Spacecraft

## 1 SUMER: Solar Ultraviolet Measurements of Emitted Radiation

Provides high resolution UV spectra to study plasma characteristics (temperatures, densities, velocities) in the chromosphere and transition region

## 2 CDS: Coronal Diagnostic Spectrometer

Provides high resolution EUV spectra to measure plasma temperatures, densities and flows in the transition region and corona

## 3 EIT: Extreme-ultraviolet Imaging Telescope

Obtains full Sun high resolution images in 4 different temperature regimes in the transition region and corona, providing the morphological context of the spectral observations of CDS and SUMER

## 4 UVCS: UltraViolet Coronagraph Spectrometer

Obtains spectroscopic observations of the extended corona out to 10 R, providing temperatures and flow velocities of hydrogen atoms, oxygen and other minor ions

## 5 LASCO: Large-Angle and Spectrometric Coronagraph

Provides images of the Sun's corona out to 30 R, revealing its evolution, activity, mass, momentum and energy input

## 6 SWAN: Solar Wind ANisotropies

Obtains full sky Ly-alpha maps to measure the latitude distribution of the solar wind mass flux and its variation in time

## 7 CELIAS: Charge, Element and Isotope Analysis System

Measures 'in situ' the elemental, isotopic and charge state composition of the slow and fast solar wind

## 8 ERNE: Energetic and Relativistic Nuclei and Electron experiment

Measures 'in situ' energy spectra of energetic particles (protons and heavier elements up to  $Z=30$ ) and abundance ratios of isotopes

## 11 MDI: Michelson Doppler Imager

Measures oscillations of the Sun's surface with high angular resolution (over 1 million pixels) to obtain information about the Sun's interior, with special emphasis on the outer layers of the Sun's convection zone. Also measures the surface's magnetic field.

## 10 VIRGO: Variability of solar Irradiance and Gravity Oscillations

Performs high sensitivity observations of solar intensity oscillations as well high precision measurements of the Sun's total energy output ("solar constant")

## 9 GOLF: Global Oscillations at Low Frequencies

Performs high sensitivity and high stability observations of full disk (low degree,  $l < 4$ ) velocity oscillations of the Sun, providing insight into the structure of the deep solar interior

## 8 COSTEP: Comprehensive SupraThermal and Energetic Particle analyser

Studies the energy release and particle acceleration processes by measuring 'in situ' energy spectra of electrons, protons and Helium nuclei

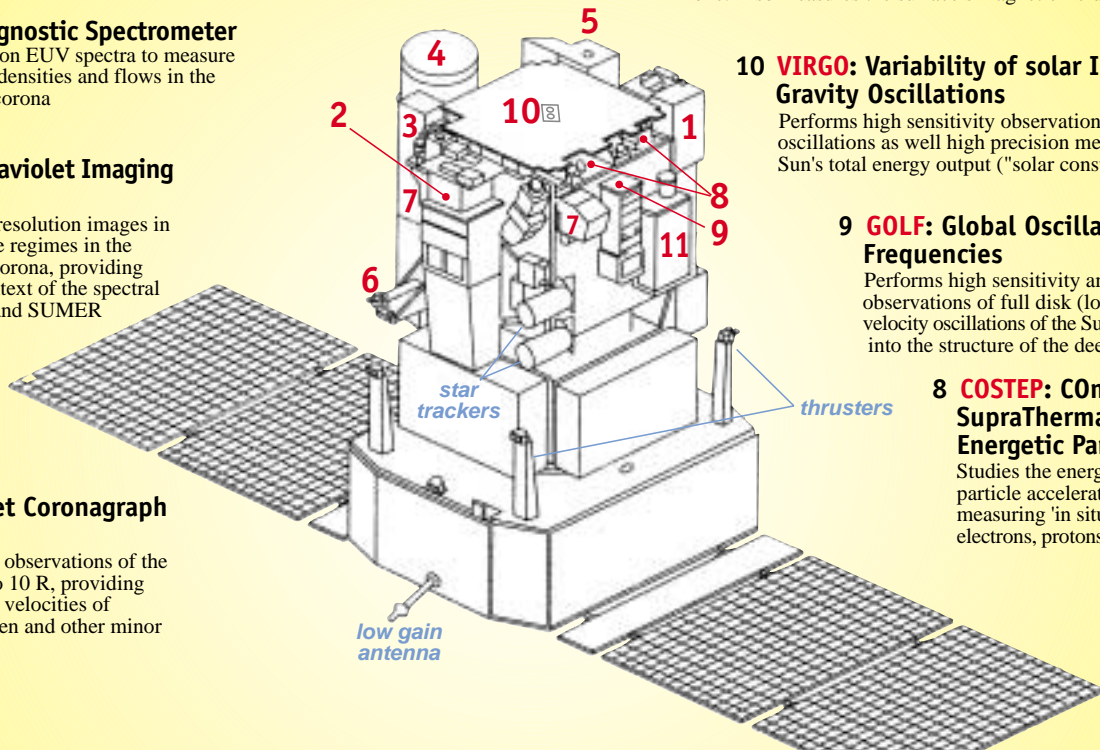

In a gentle orbit, SOHO hovers on the sunny side of the Earth, in the vicinity of Lagrange Point No. 1, where the Sun's gravity and the Earth's are in balance. This is about 1.5 million kilometers from the Earth. It follows a slow-motion orbit around this point, providing ideal conditions for continuous observations of the Sun.

